

# SHANTUI

VALUE THAT WORKS

# SG21-C6

Motor Grader



. Engine Model	Weichai WP7G220E300
. Gross Power	162kW@2200rpm
. Operating Weight	18,350kg

 **POWERSTAR**  
Polokwane



# SG21-C6 SPECIFICATIONS

## ENGINE

Model	Weichai WP7G220E300
Number of cylinders	6
Type	4-cycle, Electronic injection, water-cooled
Aspiration	Turbocharged, air-air intercooled
Bore x stroke	108x136 mm
Displacement	7.47 L
Gross power	162 kW @ 2200 rpm
Max. traction	87 kN
Max. torque	1000 N.m @ 1300-1500 rpm
Rated fuel consumption	220 g/kW.h
Emission	Stage-III

## POWER TRAIN

Transmission	Fixed-axis type, electro-hydraulic control
Torque converter	Single-stage, single-phase, three basic elements
Rear axle	Modular, planetary reduction, "no-Spin" antiskid differential
Tandem drive	Roller chain. Oscillating angle: ±15°
Tire	17.5-25 12PR
Tyre type	L-3 tube type
Front axle	Oscillating angle: ±16° Tilting angle: ±18°

## STEERING

Type	Hydraulic power
Front wheel steering angle	±50°
Articulation angle	±23°
Min. turning radius	7500 mm

## BRAKES

Service brake	Disc type, foot operated, single circuit, hydraulically actuated on four tandem wheels
Parking brake	Drum type, manually actuated

## MOLDBOARD

Rotation	360°
Moldboard width	4270 mm
Moldboard height	620 mm
Moldboard thickness	20 mm
Moldboard tip angle	22-73°
Max. cutting depth	970 mm
Max. lifting height	480 mm
Max. shoulder reach (left/right)	1900/ 1950 mm
Max. tilting angle (left/right)	±90°

## SPEED

Forward, 1-6	5.5\ 9.1\ 12.2\ 20.7\ 26.5\ 39.2 km/h
Reverse, 1-3	5.3\ 12.4\ 26.1 km/h

## HYDRAULICS

Tandem pump	Gear pump 32ml/r
Relief pressure for working equipment	18 MPa
Relief pressure for steering	16.5 MPa
Relief pressure for brakes	10MPa

## CAPACITIES

Fuel tank	360 L
Hydraulic oil tank	85 L
Engine crank case	19 L
Engine coolant	33 L

## ELECTRICAL SYSTEM

Battery	2x12V, 105Ah
Alternator	28V, 80A
Starter motor	24V, 6 kW

## OPERATING WEIGHT

Standard	18350 kg
----------	----------

## RIPPER

Ripping depth	425 mm
Shank supports	5
Shank support spacing	520 mm
Working width	2080 mm

## DIMENSIONS

A. Overall length: With rear ripper	10620 mm
B. Length: Front axle to mid tandem	6560 mm
C. Length: Between tandem axles	1540 mm
D. Height: Cab	3400 mm
E. Tread	2155 mm
F. Width: Outside tires	2600 mm
G. Moldboard width	4270 mm
H. Minimum ground clearance	400 mm

## STANDARD EQUIP

FIRE EXTINGUISHER
AIR CON
RADIO
REVERSE BUZZLE
STROBE LIGHT
REFLECTIVE TAPES
REVERSE CAMERA
INTEGRATED ROPS CAB
CAB FAN

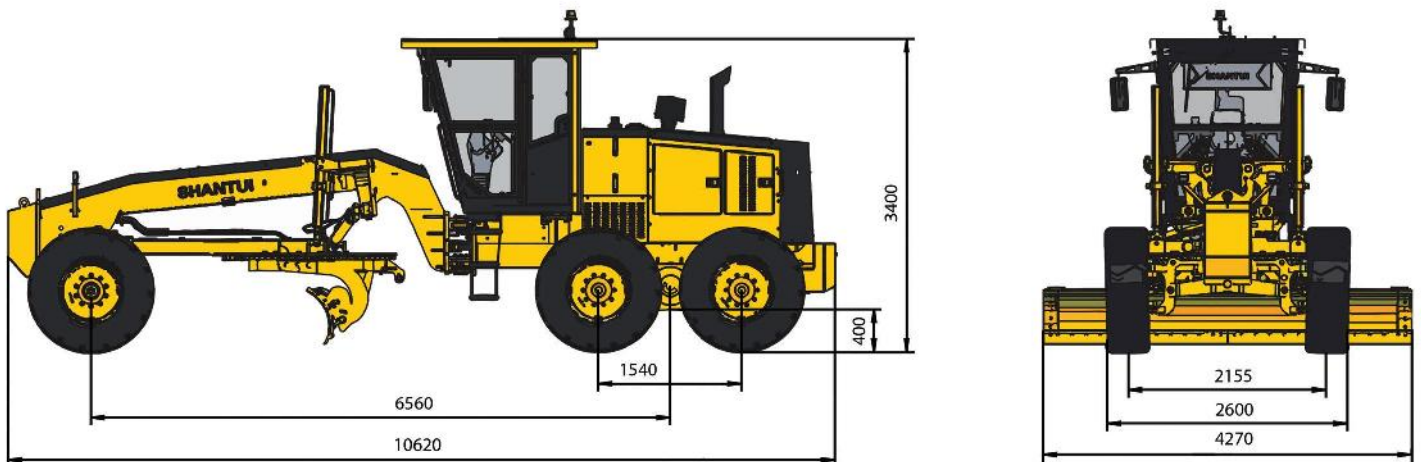

*\* Please note: The manufacturer reserves the right to make changes to the design, form, colour and specifications of any Shantui brochure without notice. The picture shown is for illustrated purposes only. \**