

Engine Cummins QSB6.7 / 6.7 L
Fuel Type Diesel
Capacity @ 600 mm LC 16,000 kg

CLG2160H

DIESEL
PNEUMATIC TIRE FORKLIFTS



TOUGH WORLD. TOUGH EQUIPMENT.

CLG2160H SPECIFICATIONS >>>

General	Model	1			CLG2160H	
	Power Type	2			Diesel	
	Base Capacity	3	@ rated load center	kg	16,000	
	Load Center	4		mm	600	
Weights	Service Weight	5	unloaded	kg	19,750	
	Axle Load	6	loaded / unloaded, front	kg	32,555 / 9,360	
		7	loaded / unloaded, rear	kg	3,195 / 10,390	
Tires	Tire Type	8			Pneumatic	
	Wheels	9	front / rear		4 / 2	
	Wheelbase	10		mm	3,500	
	Tire Size	11	front			12.00-20-18PR
		12	rear			12.00-20-18PR
	Tread Width	13	front / rear			1,844 / 2,000
Mast	Max. Fork Height	14	with std 2-stage mast	mm	4,000	
	Freelift	15	with std 2-stage mast	mm	20	
	Height, Upright Lowered	16	with std 2-stage mast	mm	3,879	
	Height, Upright Extended	17	with std 2-stage mast	mm	5,879	
	Mast Tilt, Fwd/Back	18	with std 2-stage mast	deg	6° / 12°	
	Carriage	19	width	mm	2,130	
	Fork Spread	20	minimum / maximum	mm	470 / 2,050	
	Fork Dimensions	21	T x W x L	mm	87 x 200 x 1,500	
Chassis	Length to Fork Face	22	with std 2-stage mast	mm	5,374	
	Overall Width	23		mm	2,537	
	Overhead Guard Height	24		mm	2,900	
	Turning Radius	25	minimum outside	mm	4,885	
	Fork Overhang	26	with std 2-stage mast	mm	974	
	Right Angle Stack	27	add load length and clearance	mm	7,560	
	Ground Clearance	28	minimum loaded	mm	340	
		29	center of wheelbase	mm	348	
	Performance	Travel Speed	30	loaded / unloaded	km/h	23 / 26
Lift Speed		31	loaded / unloaded	m/s	0.33 / 0.41	
Lower Speed		32	loaded / unloaded	m/s	0.32 / 0.34	
Max. Drawbar Pull		33	loaded	kg	11,100	
Max. Gradeability		34	loaded / unloaded	%	28 / 26	
Systems	Brakes	35	service		Foot / Hyd	
		36	parking		Button / Hyd	
		37	manufacturer		Cummins	
	Engine	38	model			QSB6.7
		39	emission compliance			EU Stage IIIA
		40	cylinders			6
		41	displacement	liter		6.70
		42	rated power	kW/rpm		129 / 2,200
		43	max. torque	N-m/rpm		800 / 1,400

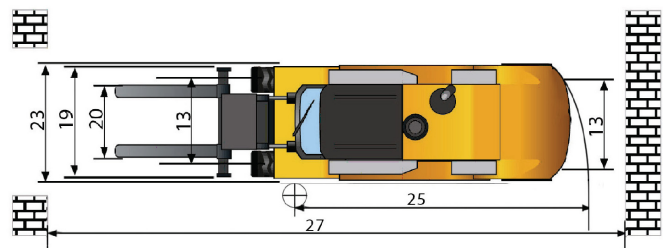
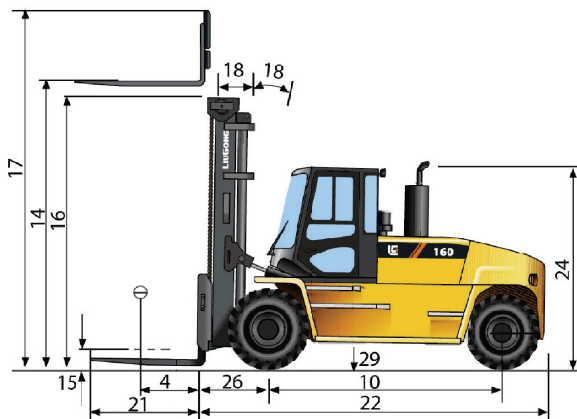

Guangxi Liugong Machinery Co., Ltd.

No. 1 Liutai Road, Liuzhou, Guangxi 545007, PR China
T: +86 772 3886124 E: overseas@liugong.com
www.liugong.com

06/2017 Designed by LiuGong

Specifications and designs are subject to change without notice. Machines shown may include optional equipment.